

STAINLESS STEEL

Sanitary TURBINE VIBRATOR

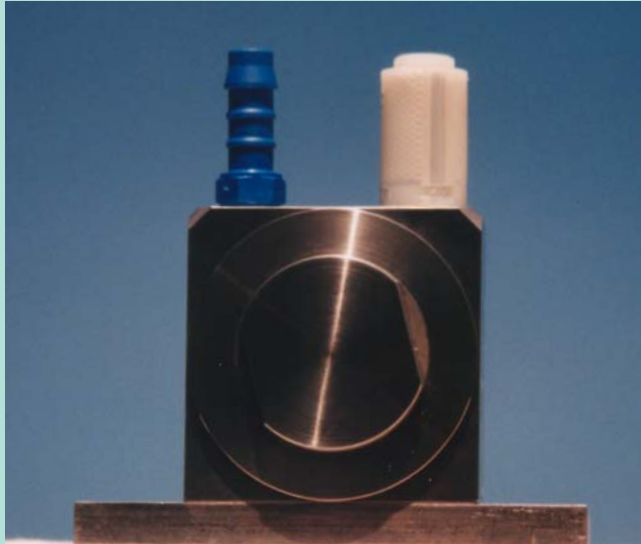

Design

The vibration is produced by the centrifugal force of the positive and negative unbalanced moments in the rotor.

The rotor is supported on two heavy duty, prelubricated, matched shielded ball bearings. Special long life grease ensures a long working life.

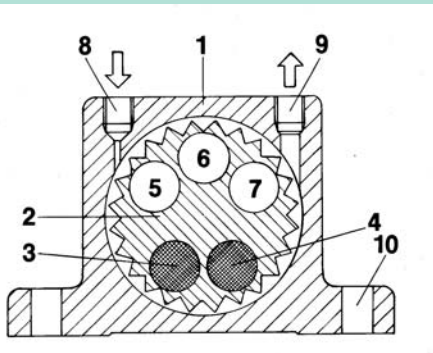

1. Stainless Steel 316L body
2. Hardened aluminum rotor.
- 3-4. Brass weights.
- 5-6-7. Cavities giving negative moment.
10. Standard bolt holes.
8. BSP tapped air inlet.
9. BSP tapped air exhaust.



How It Works

The Turbine Vibrator has an aluminum wheel with pressed in brass weights which develop the eccentric force. It spins on a shaft connected to an endplate and is supported by two bearings.

Features

All housing and parts in contact are in **Stainless Steel 316L**

Sanitary Finishing

Noise level never exceeds 75 dba

Bearings come pre-greased, no lubrication required.

Bearings are oversized to dramatically increase vibrator life.



Benefits

No metal-to-metal contact reduces noise and wear.

Because vibrator life is determined primarily by the bearing life, regular replacement of the bearings can extend the life of the vibrator.

Stainless Steel body construction and absence of airline lubrication allows use in many special environments such as food, chemical and pharmaceutical industries.

Can operate under adverse conditions such as grit, water, rust, heat and cold.

Will not rust in extremely humid conditions.

Withstands corrosive conditions.

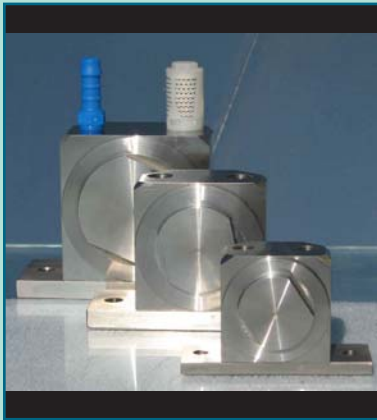

APPLICATIONS

With 316L construction these special vibrators are ideal for the most demanding conditions.

Environments

Contamination free
Corrosion free
Easy cleaning

Industries

Food
Chemical
Pharmaceutical

PERFORMANCE DATA

MODEL	FREQUENCY			FORCE OUTPUT			AIR CONSUMPTION		
	30 PSI	60 PSI	90 PSI	30 PSI	60 PSI	90 PSI	30 PSI	60 PSI	90 PSI
	vpm	vpm	vpm	lbs	lbs	lbs	cfm	cfm	cfm
GT 10 SS	27000	34000	37000	190	290	520	2	3	4
GT 16 SS	16000	21000	23000	290	450	700	4	7	10
GT 25 SS	12000	16000	18000	450	780	990	6	12	16
GT 25 SS/S	8000	11000	13000	500	800	1150	6	12	16

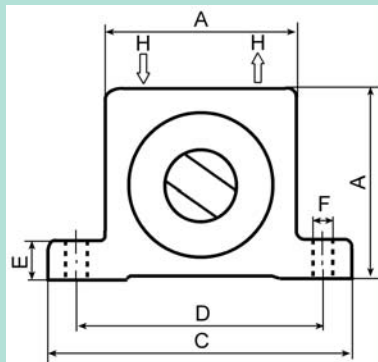

WITH BASE

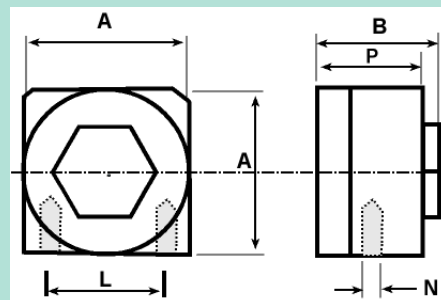

WITH NO BASE

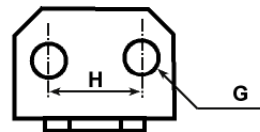

DIMENSIONS

MODEL	A	B	C	D	E	F	G / H	L	N	P	Weight
GT 10 SS	1.93"	1.18"	3.39"	2.68"	0.27"	0.28"	1/8"	1.42"	M 6	1.26"	1.5 lbs
GT 16 SS	2.52"	1.57"	4.33"	3.54"	0.39"	0.35"	1/4"	1.89"	M 8	1.53"	2.2 lbs
GT 25 SS	3.07"	1.97"	4.96"	4.09"	0.39"	0.35"	1/4"	2.36"	M 10	1.93"	4.0 lbs
GT 25 SS/S	3.07"	1.97"	4.96"	4.09"	0.39"	0.35"	1/4"	2.36"	M 10	1.93"	5.0 lbs

Chicago Vibrator Products
Flow and Compaction

Division of CVP Group
800-842-7284 (P)
866-247-7538 (F)
Solutions@ChiVib.com
www.ChicagoVibrator.com